

FUJITSU Cassette Type

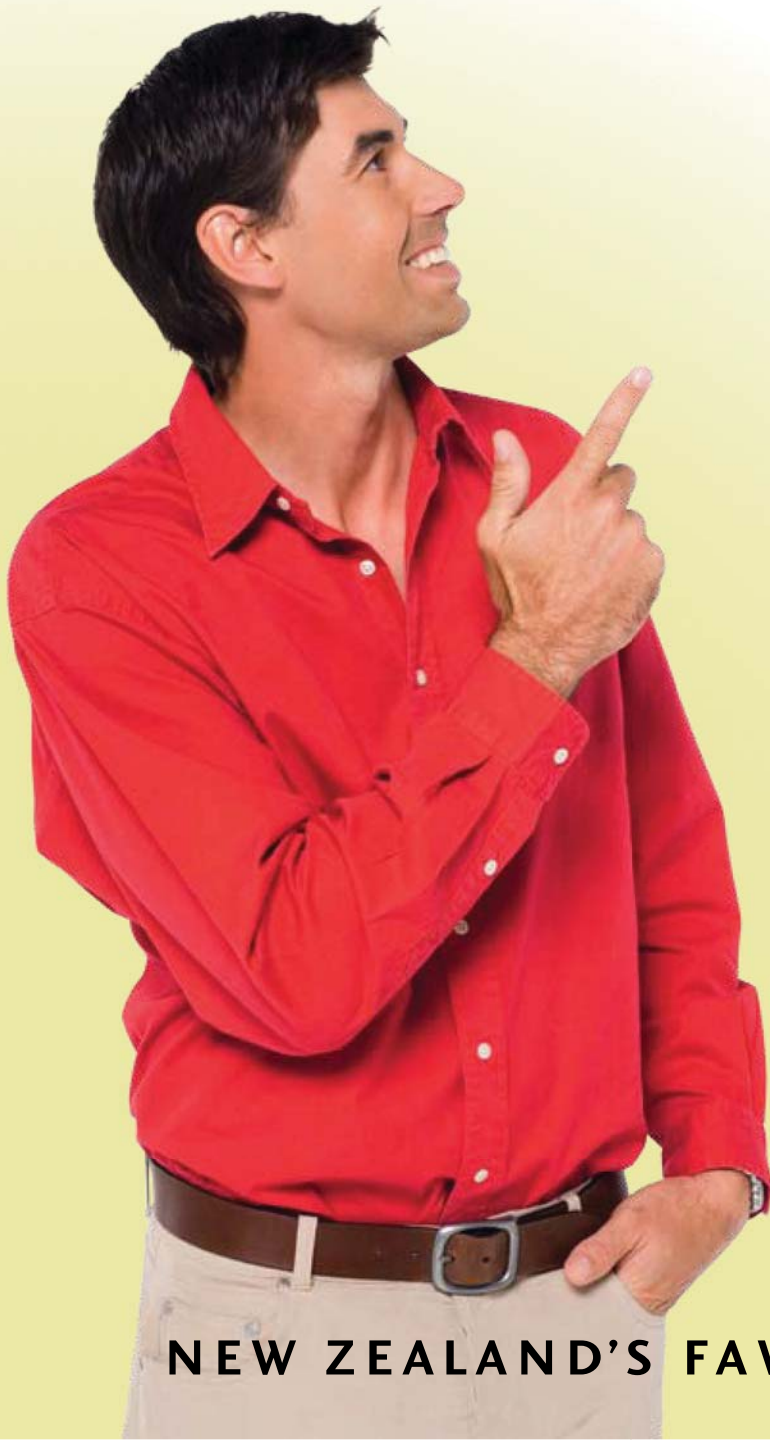

NEW ZEALAND'S FAVOURITE AIR™



Cassette Type Split Systems are extremely discreet, with only the grille showing in the ceiling. They provide heating and cooling in a full range of capacities. DC technology is used to deliver high energy efficiency, with 5 STAR ratings - qualifying for the Blue Energy Star. Other features include Quiet Mode, air filter maintenance indicator and built-in condensate pump.

INVERTER

Compact Cassette

INVERTER

Cassette

The Compact Cassette is elegant and compact, yet efficient, quiet and very effective.

Compact size. (AUTA18L/24L)

Compact grille fits common ceiling panel (590 x 590mm).

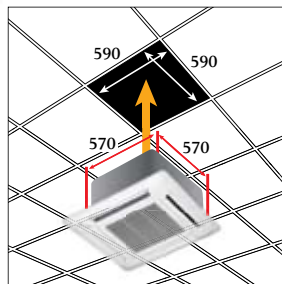

3 or 4-Way air distribution. (AUTA18L/24L)

The number of air outlets can be configured.

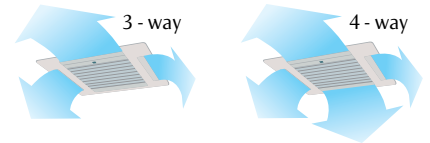

Infra-red remote control features:

- 4 built-in timers (On / Off / Program / Sleep).
- Program timer operates the ON and OFF timer once within a 24 hour period
- Economy button
- Filter re-set button
- Swing louver operation



Air Flow. (AUTA18L/24L)

Air reaches whole room even with 3.5m high ceilings.

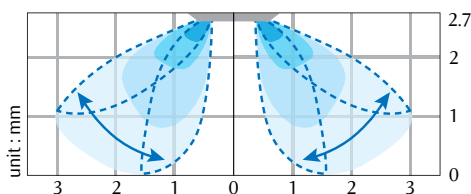

Air is spread widely to reach room corners.



AUTA18L/24L





Infra red remote control





(Optional) Wired controller with weekly/set-back timer



For AUTA18L/24L

AUTA18L  

C 5.2kW / 17,700BTU/h
H 6.0kW / 20,500BTU/h

AUTA24L  

C 7.1kW / 24,200BTU/h
H 8.0kW / 27,300BTU/h



AUT30L/36L/45L



Infra red remote control (optional)



Wired controller (with weekly/setback timer)





For AUT30L





For AUTA36L/45L

AUT30L  

C 8.5kW / 29,000BTU/h
H 10.0kW / 34,100BTU/h

AUTA36L  

C 10.0kW / 34,100BTU/h
H 11.2kW / 38,200BTU/h

AUTA45L  

C 12.5kW / 42,700BTU/h
H 14.0kW / 47,800BTU/h

The larger Cassette models have the power to heat and cool large spaces, yet are still discreet, very quiet and now super efficient.

Fresh air.
(AUT30, AUTA36/45)

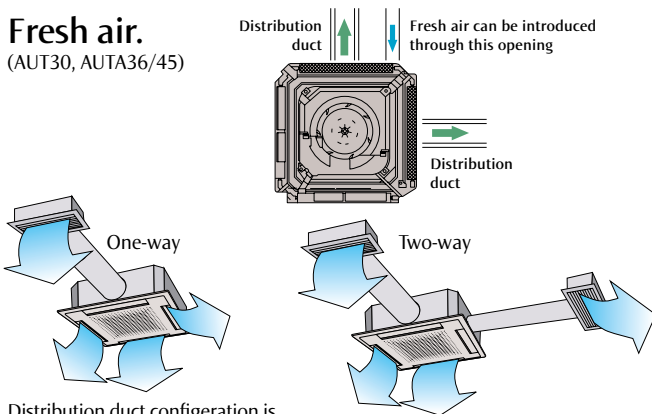

Distribution duct configuration is designed for efficient air distribution in larger areas

Cobalt blue heat exchanger. (AOT30L, AOTA36L/45L)

The outdoor unit fins are coated with a blue corrosion resistant material to enhance durability and extend performance life of your heat pump.

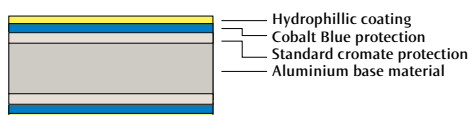

Easy-to-understand operation.

The operation / display sections are zoned according to time and operation, enabling variable programming to match application.

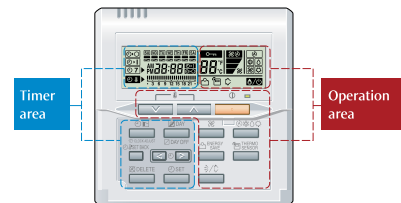

Wired controller features:

- Various timer set-up
- Weekly timer (2 x start and 2 x stop settings per day)
- Set back timer
- Group control of up to 16 indoor units
- Built-in thermosensor
- Child lock
- Filter maintenance display
- Memory back up setting

SPECIFICATIONS

Type			Inverter	Inverter	Inverter	Inverter	Inverter	
Model No.	Indoor Unit		AUTA18ALAU	AUTA24ALAU	AUT30LUAS	AUTA36LATU	AUTA45LATU	
	Outdoor Unit		AOTA18LAACL	AOTA24LAACL	AOT30LNAWL	AOTA36LATL	AOTA45LATL	
Reverse Cycle			Yes	Yes	Yes	Yes	Yes	
Cooling Capacities	Watts		5,200	7,100	8,500	10,000	12,500	
	BTU/Hr		17,700	24,200	29,000	34,100	42,700	
Cooling Range	Watts		900 - 5,900	900 - 8,000	3,000 - 10,000	3,800 - 11,200	4,000 - 14,000	
	BTU/Hr		3,100 - 20,100	3,100 - 27,300	10,200 - 34,100	13,000 - 38,200	13,700 - 47,800	
Heating Capacities	Watts		6,000	8,000	10,000	11,200	14,000	
	BTU/Hr		20,500	27,300	34,100	38,200	47,800	
Heating Range	Watts		900 - 7,500	900 - 9,100	3,000 - 11,200	4,000 - 14,000	4,200 - 16,200	
	BTU/Hr		3,100 - 7,500	3,100 - 31,000	10,200 - 38,200	13,700 - 47,800	14,300 - 55,300	
Star Rating	Cool		5	4.5	4	5	5	
	Heat		5	5	5	5.5	5.5	
E.E.R Cool	W/W		3.21	3.21	2.97	3.21	3.21	
C.O.P Heat	W/W		3.61	3.61	3.52	3.71	3.66	
Running Current	Cool	Amps	7.1 (9.1 Max)	9.7 (11.5 Max)	12 (14.6 Max)	13 (19 Max)	16.3 (20 Max)	
	Heat	Amps	7.3 (11.1 Max)	9.7 (12.3 Max)	11.9 (14.6 Max)	12.7 (19 Max)	16.1 (20 Max)	
Input Power	Cool	Watts	1,620 (90 - 2,070)	2,210 (90 - 2,610)	2,860 (1,080 - 3,500)	3,110 (4,540 Max)	3,890 (4,780 Max)	
	Heat	Watts	1,660 (90 - 2,520)	2,210 (90 - 2,800)	2,840 (1,000 - 3,500)	3,020 (4,540 Max)	3,830 (4,780 Max)	
Moisture Removal	L/Hr		2.2	2.7	3	3.5	4.5	
Fan Speeds			4	4	3	4	4	
Air Circulation	l/s		222	258	430	458	486	
Indoor Sound	Quiet	DbA at 1m	30	33	N/A	36	39	
	Low	DbA at 1m	34	40	41	41	42	
	Pressure Level	Med	DbA at 1m	38	45	44	46	
Outdoor Sound Pressure Level	High	DbA at 1m	43	49	48	50	52	
	DbA at 1m		50	53	55	55	56	
Dimensions and Weights	I.U	Height	mm	245	245	296	296	296
		Width	mm	570	570	830	830	830
		Depth	mm	570	570	830	830	830
		Net Weight	kg	15	17	37	39	39
	O.U	Height	mm	790	790	830	1290	1290
		Width	mm	300	315	900	900	900
		Depth	mm	578	578	330	330	330
		Net Weight	kg	40	44	64	98	98
Compressor Type			Twin Rotary	Twin Rotary	DC Twin Rotary	DC Rotary	DC Rotary	
Indoor Unit Hole Cutout Size	mm		580 - 660	580 - 660	890 x 890	890 x 890	890 x 890	
Interconnect cables - size	Qty - mm2		4 - 1.5	4 - 1.5	4 - 1.5	4 - 1.5	4 - 1.5	
Recommended Min. Power Cable	mm2		2.5	4	4	6	6	
Phase - Frequency	Ph - Hz		1 - 50	1 - 50	1 - 50	1 - 50	1 - 50	
Power Supply Attachment			Outdoor	Outdoor	Outdoor	Outdoor	Outdoor	
Power Supply	Volts		230	230	230	230	230	
Refrigerant Type			R410a	R410a	R410a	R410a	R410a	
Connection Pipe Sizes	Gas	mm	12.7	15.88	15.88	15.88	15.88	
	Liquid	mm	6.35	6.35	9.52	9.52	9.52	
Minimum Pipe Length	Metre		5	5	5	5	5	
Maximum Pipe Length	Metre		25	30	50	50	50	
Maximum Pipe Height	Metre		15	20	30	30	30	
Pre Charged Length	Metre		15	15	15	20	20	
Pipe Connection Method			Flare	Flare	Flare	Flare	Flare	
Condensate Pump Lift	mm		700	700	800	800	800	
Outdoor Operating Temp	Cool	Degree C	-10 to 46	-10 to 46	-10 to 43	-15 to 46	-15 to 46	
	Heat	Degree C	-15 to 24	-15 to 24	-10 to 24	-10 to 24	-15 to 24	
Grill			UTG-UFYA-W	UTG-UFYA-W	Supplied	Supplied	Supplied	



NEW ZEALAND'S FAVOURITE AIR™

Fujitsu General New Zealand Limited
www.fujitsugeneral.co.nz

Products depicted in this brochure contain high operating pressure R410a refrigerant. It is illegal to vent that refrigerant to the atmosphere. Only persons qualified and experienced in the installation, service and repair of these products are authorised to undertake such work.

Fujitsu General Accredited Installers have shown they have the necessary equipment and have accepted responsibility for their installations and the requirements of any statutes or laws.

Due to ongoing Research and Development specifications and designs are subject to improvement without notice therefore relevant manuals must be consulted before any action is taken to install or service these products

Heating/Cooling capacities and run current tests are based on the requirements of AS/NZS3283, that standard tests at the temperature below.

COOLING: Indoor Temp: 27°C DB / 19°C WB
Outdoor Temp: 35°C DB

HEATING: Indoor Temp: 20°C DB
Outdoor Temp: 7°C DB / 6°C WB

As actual temperature ranges in New Zealand vary considerably only competent people should provide advice as to size and placement of units.

Sound power level is tested to AS/NZS1217.

Recommended cable sizes are based in AS/NZS3000 and AS/NZS3008.

Fujitsu General New Zealand Ltd warrants the equipment against any defects in materials and factory workmanship for a period of five years from the date of installation, or for 6 years if installed by an Accredited Installer.

This warranty does not cover defects or failures which are attributable to; incorrect or improper installation; environmental damage; airflow restriction; inadequate electrical supply; getting access to the product.

EXPLANATION OF FEATURES (MODEL DEPENDENT)

<p>Moisture Removal The computer effectively dehumidifies the air.</p>	<p>Auto Restart In the event of a temporary power failure, the air conditioner will automatically restart in the same operating mode as before, once the power supply is restored.</p>	<p>ON-OFF Timer ON-OFF timer can be set to operate once.</p>	<p>Control Port External inputs and outputs contained within the product allow on/off control.</p>
<p>Up/Down Swing Louvers The up/down louvers automatically swing to up and down.</p>	<p>Auto-Changeover The unit automatically switches between heating and cooling modes based on your temperature setting and the room temperature.</p>	<p>Weekly Timer Different on-off times can be set for each day.</p>	<p>Washable Panel</p>
<p>Automatic Louvers The position of the louvers is set automatically to match the operating mode. It is also possible to adjust the louvers using the remote control.</p>	<p>Sleep Timer The micro-computer gradually changes the room temperature automatically to afford a comfortable night's sleep.</p>	<p>Weekly + Setback Timer Weekly + Setback timer can set temperature for two time spans and for each day of the week.</p>	<p>i PAM Fujitsu's advanced inverter technology now includes i PAM (Intelligent Power Module-Pulse Amplitude Modulation), to enable high output and high efficiency.</p>
<p>Auto Shut Louvers The auto shut louvers close or open automatically when the unit stops or starts.</p>	<p>Program Timer This digital timer allows selection of one of four options. ON, OFF, ON → OFF, or OFF → ON.</p>	<p>Connectable Distributing Duct Conditioned air can be distributed by means of a distributing duct.</p>	<p>Top Energy Saver Award For the most energy efficient Star Rated Products.</p>
<p>Automatic Air Flow Adjustment The micro-computer automatically adjusts the air flow effectively to follow the changes of room temperature.</p>		<p>Connectable Fresh Air Duct Duct connection port hole opening. Fresh air can be introduced through this opening.</p>	<p>C Cooling H Heating</p>

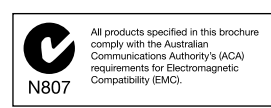

5 Year full parts and labour warranty. 6 years (an extra full year's warranty) when you use a Fujitsu Accredited installer.